

# STRINGO®

THE ORIGINAL VEHICLE MOVER



## Stringo S3

YOU CHOOSE THE DIRECTION  
WE'LL DELIVER THE POWER

The Stringo S3 is intended for those seeking a powerful vehicle mover that is easy to service and has a long operating time. The machine provides you with a good overview and features the optimal setup for the safe and smooth maneuvering of vehicles weighing up to **3 000 kg** (6 615 lb).

**THE STRINGO S3** is the ideal choice for businesses that have to regularly move vehicles some distance, for example automotive industry testing labs, end-of-line, and larger workshops. The Stringo S3 is also a wise choice for dealer showrooms and businesses that handle heavier and larger SUVs weighing between 2 000 (4 410 lb) and 3 000 kg (6 615 lb).

With an operating time of ten hours and a battery and a motor with minimal maintenance requirements, the Stringo S3 is a tough work tool. Our wide range of accessories means we are able to adapt the machine to suit your specific requirements. S3 is available with hydraulic cylinder for greater power and it allows a lower ground clearance for really low cars.

**OTHER ADVANTAGES INCLUDE** the modern design of the S range of machines, which has resulted in safer working practices and an improved working posture for the operator.

“Every Stringo is adapted from creation according to its future owner’s specific needs.”

All Stringo Models can be equipped with a wide range of options in order to meet the customer's individual needs.

## Customized solutions

As a company, we have been around since the 1980-ties and have many years worth of experience in the vehicle moving equipment industry and are experts in adapting our vehicle moving equipment to fully meet the specific needs of our customers.

The Stringo series is designed to work to it's full capacity when customized to the environment it is intended to serve, as well as the type of cars it is intended to transport. We are here to help you obtain a Stringo model accommodated to your needs. Our standard is customized.

### Technical Data **Stringo S3**

#### WEIGHT INFORMATION

Service weight	430 kg / 950 lb
Max load – vehicle axle weight	1 800 kg / 3 970 lb
Train weight	3 430 kg / 7 560 lb

#### ELECTRIC SYSTEM

Motor output	1 200 W
--------------	---------

#### BATTERY

Battery type	Traction
Battery capacity	2 x 150 Ah C20

#### PERFORMANCE

Speed	Dual speed 0-3 km/h / 1.9 mph and 0-6 km/h / 3.7 mph
Operating time/Charge	10h

#### WHEEL SYSTEM

Drive wheel	Ø 250 x 80 mm / Ø 9.85 x 3.15 in
-------------	-------------------------------------

#### STANDARD DIMENSIONS

Length (A)*	1 750 mm / 68.90 in
Drive unit measurement (B)	425 mm / 16.75 in
Outside measurement (F)	1 850 mm / 72.85 in
Inside measurement (G)	1 130 mm / 44.50 in

\* Telescopic function adds additional 400 mm / 15.80 in

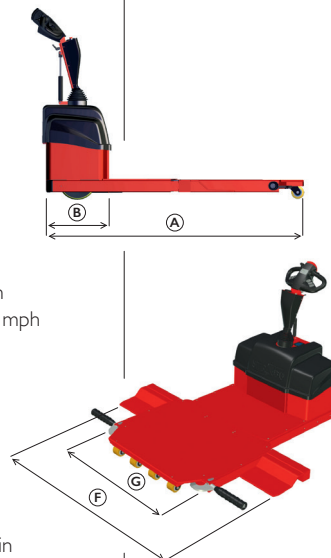

## Options



#### FOLDABLE ROLL PROTECTORS

To prevent cars with small wheels to roll off the inclined planes. Can be folded backwards to allow for large wheels.



#### RIDE-ON PLATFORM

Can be lowered to enable the operator to ride on it during longer movements.



#### ROLLER PLANES

Allow the wheel pair to rotate during transportation. Necessary when moving 4 WD vehicles and vehicles with blocked wheels.

Few and short movements

STRINGO S2

Vehicles up to  
2 000 kg/4 410 lb

STRINGO S3

Vehicles up to  
3 000 kg/6 615 lb

STRINGO 550

Vehicles up to  
5 000 kg/11 020 lb

Frequent and/or long movements

FOR MORE PRODUCT INFORMATION AND CONTACT, PLEASE VISIT OUR WEBSITE AT [STRINGO.COM](http://STRINGO.COM)